

Ternate, 18 September 2023

Submission Id : 6534  
Letter of Acceptance

Dear:

**Dio Wahyu Pratama, Muhamad Ariandi**

We have reached a decision regarding your submission to PROtek : Jurnal Ilmiah Teknik Elektro P-ISSN 2354-8924 dan E-ISSN 2527-9572. **Titel : Prototype of Safety System Monitoring on Komatsu PC 200-7 Excavator Using Microcontroller**

**Our decision is to: Accepted Submissions**

Based on the review results, the article will be published in PROtek : Jurnal Ilmiah Teknik Elektro. Volume 11 Nomor 1 January 2024. The article is available online at <http://ejournal.unkhair.ac.id/index.php/protek>

This information is conveyed, and for your attention, thank you

Editor In Chief



**Dr. Iis Hamsir Ayub Wahab, M.Eng., IPU**

INDEXED IN



# Prototype of Safety System Monitoring on Komatsu PC 200-7 Excavator Using Microcontroller

\*Muhamad Ariandi

Department of Electrical Engineering, Faculty of Engineering, Binadarma University. Palembang, Indonesia

email: muhamad\_ariandi@binadarma.ac.id

Dio Wahyu Pratama

Department of Electrical Engineering, Faculty of Engineering, Binadarma University. Palembang, Indonesia

email : [saputradio662@gmail.com](mailto:saputradio662@gmail.com)

**Abstract :** PC200-7 Excavator is a type of excavator that still does not have an effective and efficient safety system monitoring in knowing the oil level and overheating that occurs. Given this, researchers designed and made a prototype of a tool that could later be applied to the excavator industry, by adding several sensor components such as ultrasonics and thermocouples that are useful for checking hydraulic oil levels so that drivers do not struggle to check manually and check the temperature on the engine to avoid *overheating* by setting a normal temperature height limit. If it exceeds the normal temperature limit, the engine of the excavator will die. To prevent damage to the engine, the temperature on the prototype was made a limit of 40 °C. If there is a human behind the excavator, it will be detected with a distance of 200 cm by the ultrasonic sensor. So that the results obtained are able to monitor the oil level, if less than the specified limit of 3cm, and the temperature on the engine will be automatically detected if the engine temperature is above 40 °C automatically turns off and gives a warning to the driver in the cabin in the form of a writing message and sound from the buzzer. For the detection of human objects behind the excavator will be active if there is a human object with a distance of less than 200 cm, then the buzzer will turn on, then give a notification writing on the LCD in the cabin and the excavator will stop, but the engine still starts. In this research method, measurements and calculations will then be compared with *datasheets*. Calculation results were obtained for Ultrasonic sensors 5.16 V<sub>DC</sub>, for Thermocouple sensors 3.148 V<sub>DC</sub>. and for RFID 3.278 V<sub>DC</sub>.

**Keywords:** *Monitoring, Excavator, Ultrasonic Sensor, Thermocouple Sensor, Esp 32*

## I. INTRODUCTION

The country of Indonesia is rich in abundant natural resources, where the wealth of natural resources is spread throughout the territory of Indonesia. Thus, Indonesia should have no difficulty in working or processing these abundant natural resources. Among all the natural wealth available, the most promising wealth to manage is in the mining sector, considering that it only needs to take the most treasure in the bowels of the earth, absorb labor, excite so many supporting sectors, and the selling value of the products taken is so valuable. Indonesia is rich in mining areas, including: coal mines, gold mines, nickel mines, sand mines, oil and gas mines, asphalt mines, and various other mineral mines. To carry out the mining process, various kinds of Heavy Equipment are used, one of which is an Excavator.

Komatsu PC200-7 Excavator is a 20-ton class 7 series Excavator that is often used in mining and agricultural land. When in the process of work, security is mandatory for workers and their work tools. For this type of excavator there is still no warning device that should be on the excavator, such as to protect the engine from damage caused by hot radiator water so that there is no early warning to prevent it from happening, then for the lack of hydraulic oil that can cause damage to hydraulic components there should be a warning when the oil level is less than the specified limit and there must be an automatic warning when there is Humans behind excavators are not visible to drivers in the cabin, it can cause work accidents when the excavator is operating.

In the journal that makes "Prototipe sistem peringatan pengemudi ekskavator terhadap area kerja sekitar berbasis sensor ultrasonik dan mikrokontroler arduino uno" This research made a prototype warning system on excavators using ultrasonic sensors to find out objects around the excavator[1]. Then in a research journal entitled "Aplikasi Internet of Thing monitoring suhu engine untuk mencegah terjadinya overheat"

This research aims to create and design an *online temperature monitoring engine* system based on the *Internet of Things*[2]. "Prototype of Safety System Monitoring on Komatsu PC 200-7 Excavator using Microcontroller" to assist excavator drivers in monitoring the temperature of the engine to avoid overheating, monitor the movement behind the excavator when there are objects that obstruct or to prevent work accidents, monitor the hydraulic oil level in the tank so as not to cause hydraulic oil shortages that have an impact on damage to the main pump or main pump, and use an RFID system for additional security and will issue information on the LCD.

## II. RESEARCH METHODS

### A. Transmitter

Transmitter is a system in the world of control systems and sensors, this transmitter is a tool used to hold the output signal of the transducer or sensor so that it can be received by the controller. In glue 1 is a schematic circuit for the Transmitter in the Safety System Prototype on the Komatsu PC200-7 Excavator using a Microcontroller:

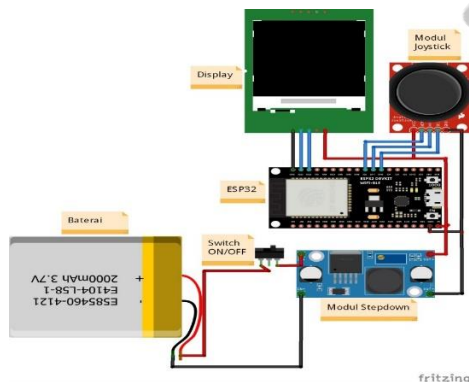

Figure 1 Schematic Circuit on Device Transmitter

### B. Receiver

The receiver concept is ubiquitous and applies to all types of receivers in all forms of technology. All receivers can receive anything from the transmitter in the form of electromagnetic waves, electrical signals, sound waves, or sound waves without exception. In figure 2 is the schematic circuit for the receiver in the Safety System Prototype on the Komatsu PC200-7 Excavator using a Microcontroller:

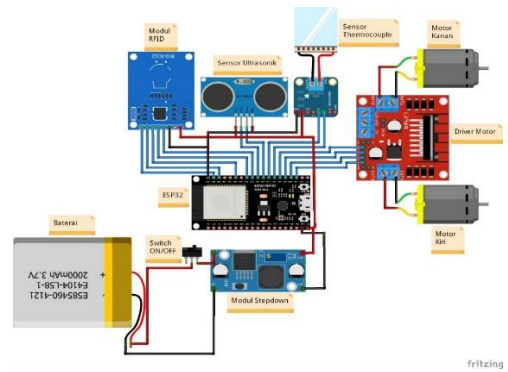

Figure 2 Schematic Circuit on Device Receiver

In figure 3 and figure 4 are block diagrams of the Transmitter and Receiver of the tool to explain the process that occurs in the prototype of this research tool consisting of 3 things, namely Input, Process, and Output, where each of these three things is very important in making a prototype of this tool.

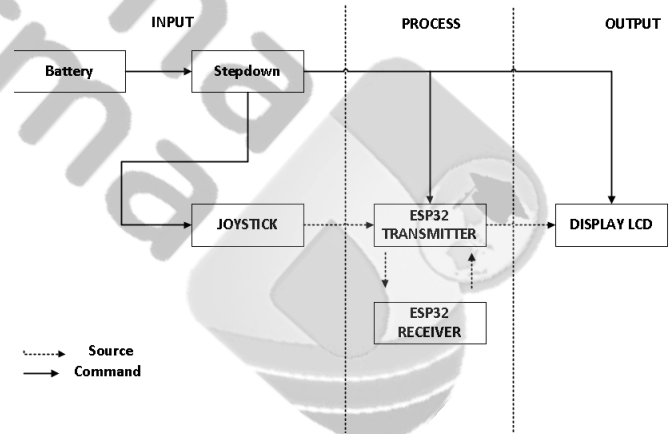

Figure 3 Block Transmitter Diagram

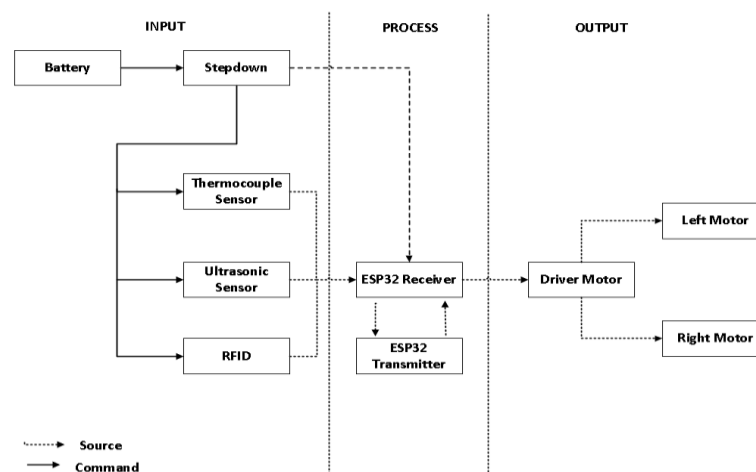

Figure 4 Receiver Block Diagram

### C. How the Tool Works

At "Prototipe Monitoring Sistem Pengaman Pada Excavator Komatsu PC 200-7 Menggunakan Microcontroller" It uses MAX6675 Thermocouple sensor, HY-SRF05 Ultrasonic sensor, RFID Module, Transmitter and Receiver. For the main source using a 7.4 V Li-ion Battery. How the Tool Works as follows :

1. When turning on the device, the RFID reader component must first read the tag from RFID that has been configured in the program, after the RFID tag is read, the device can be turned on or in the system position ON.
2. When the tool is on or on, the Thermocouple sensor will read the engine temperature, when the engine temperature is above 40°C, Then automatically the machine will turn off. To avoid overheating of the engine.
3. Ultrasonic sensor 1 which functions to check the hydraulic oil level in the tank when it is ready and read the oil level if the oil level is less than the specified capacity then the engine will automatically turn off by itself, as well as when the tool is on and operating when suddenly the hydraulic oil level decreases due to oil leakage, the engine will shut down. Because if the lack of oil will have an impact on damage to the components in the main pump or hydraulic oil pump.
4. Ultrasonic sensor 2, serves as a safety when suddenly an object at the back or blind spot on the excavator is detected, then the engine will automatically stop, objects here such as objects that interfere with the speed of the excavator to move or humans that can result in being run over or hit by the back of the excavator, when the object is no longer there then the machine is ON again.
5. All notifications from the sensors that are read will immediately appear on the LCD on the transmitter.

## III ANALYSIS RESULTS

### A. Equipment Work Test Results

In Figure 5 it is explained when the device is turned on, the engine and all sensors installed will also be active. Then the LCD will display the state of the sensor.



Figure 5 Lcd display when normal

When the driver has operated the tool, 3 (three) indicators begin to check, namely ultrasonic sensor 1 for hydraulic oil level, ultrasonic sensor 2 for object detection behind the tool, and thermocouple sensor for temperature on the engine. Then in figure 6 it is explained that when the oil level is less than the specified limit, the engine of the tool will turn off and cannot move, then it will send a notification in the form of a sound on the buzzer and a warning on the LCD to show that the oil is lacking.



Figure 6 Lcd display when oil is lacking

In figure 7 shown when the temperature on the engine exceeds 40°C. The engine temperature exceeds 40°C, the tool stops and will send a notification in the form of a sound on the buzzer and a warning on the Lcd to indicate that the engine temperature is above 40°C, and will be turned back on again after the temperature drops below 40°C.



Figure 7 Lcd display when temperature above 40oC



Then in figure 8 to detect the object behind the tool, when the object is detected with a distance of more than 20cm, the buzzer notification will sound and send a warning to Lcd, then after the object disappears, the tool will be able to move again as before.



Figure 8 Lcd display when there is an object behind the device

In figure 9 below is the overall picture of the prototype of the tool that has been made.



Figure 9 Tool Prototype

### B. Measurement

Testing or measuring of components is carried out five times, in order to get accurate results. Furthermore, the average data will be obtained using the formula below :

$$\bar{x} = \frac{x_1+x_2+x_3+x_4+x_5}{n} = \frac{\sum x_i}{n}$$

Keterangan :

- $\frac{\sum x_i}{n}$  = Number of all samples
- $x_i$  = Measurement
- $n$  = Number of measurements
- $\bar{x}$  = Average Price

Table 1. Component Measurement Results

Component	V <sub>DC</sub>
Battery	8,066
Step down	5,18
Esp 32	3,328
RFID	3,278
Ultrasonic 1	5,16
Ultrasonic 2	5,14
Thermocouple	3,148
LCD	3,3

### C Error Percentage

From the results of measurements that have been carried out as the data above, there is an average value at each measurement point. This value has a function to get the percentage error value on the measurement. Here is a table of the results of the calculation of the percentage error of each measurement point.

Table 2. Error Percentage

komponen	Data sheet (V <sub>DC</sub> )	Perhitungan (V <sub>DC</sub> )	Presentase
Battery	7,3-8,1	8,066	In Range
Step down	4-30	5,18	In Range
ESP 32	3,3-5	3,328	In Range
RFID	2,5-3,3	3,278	In Range
Ultrasonic 1	3,3-5,5	5,16	In Range
Ultrasonic 2	3,3-5,5	5,144	In Range
Thermocouple	3-5,5	3,148	In Range
LCD	3-3,5	3,3	In Range

### D. Analyzes

From the results of measurements, calculations, and simulations from the tools that have been carried out, it can be analyzed as follows:

1. At measurement point 1, that is, on the battery which is the main source of voltage from the tool. From the average measurement results, the battery voltage is 8.066 Volts, referring to the battery data sheet, which is 7.3-8.1 Volts. Thus the battery voltage can be said to be normal, and does not exceed the tolerance limit.
2. Measurements on the ESP 32 microcontroller, ESP 32 are part of the control of this tool, then the average input voltage is 3.328 Volts, while on the ESP 32 datasheet is 3.3-5 Volts. Thus the voltage at ESP 32 is still within the In Range and safe to use.
3. For RFID that functions as a safety before running the tool, the average voltage that has been measured is 3.278 Volts. Where the datasheet of RFID is 2.5-3.3 Volts, it can be declared RFID Voltage In Range and safe to use.
4. The next measurement is Ultrasonic Sensor 1 which functions as a hydraulic oil level detector in the tank, based on measurements made, an average voltage of 5.16 Volt is obtained when the oil level is less or not. Referring to the datasheet of the ultrasonic sensor, its voltage ranges from 3.3-5 volts. Thus the ultrasonic sensor is still safe and the voltage is In Range.
5. For measurements on ultrasonic sensor 2, which is used to detect the presence of objects behind the tool, when there are objects or no objects obtained an average voltage of 5.144 Volts, and from the datasheet ranging from

3.3-5 Volts, it can be concluded that ultrasonic sensor 2, is safe to use because of its voltage In Range.

- 6 The next measurement is the Thermocouple sensor, which functions to detect engine temperature so that overheating does not occur, for the Thermocouple sensor an average voltage of 3.148 is obtained. Then in the Thermocouple sensor voltage datasheet ranges from 3-5.5 Volts, it can be stated that the Thermocouple sensor is safe to use because the voltage is still In Range.
- 7 For the latter is the Lcd display which is used to see notifications from all sensors and to give warnings to the rider. The average voltage obtained from the LCD is 3.3 Volts, then on the datasheet the voltage ranges from 3.3-5 Volts, thus it can be stated that the Lcd can be used and the voltage is In Range.

#### IV CONCLUSION

The results of research that have been carried out related to the prototype of monitoring the safety system on the Komatsu PC200-7 excavator using a microcontroller as a whole, the sensor components function according to their respective functions and are good with the measurement result value limited to a tolerance threshold of about 5%

#### REFERENCE

- [1] R. Yulianto *et al.*, "PROTOTIPE SISTEM PERINGATAN PENGEMUDI EKSAVATOR TERHADAP AREA KERJA SEKITAR BERBASIS SENSOR ULTRASONIK DAN MIKROKONTROLER ARDUINO UNO.", 2021.
- [2] J. Teknik Mesin, P. Studi Alat Berat, P. Negeri Balikpapan, J. Soekarno Hatta Km, and K. Timur, "APLIKASI INTERNET OF THINGS MONITORING SUHU ENGINE UNTUK MENCEGAH TERJADINYA OVER HEAT," vol. 7, no. 2, 2018.
- [3] F. Z. Rachman, "Sistem Pemantau Gas di Tempat Pembuangan Sampah Akhir Berbasis Internet of Things," *Jurnal Teknologi dan Sistem Komputer*, vol. 6, no. 3, pp. 100–105, 2018.
- [4] D. Susandi, W. Nugraha, and S. F. Rodiyansyah, "Perancangan smart parking system pada prototype smart office berbasis internet of things," *Prosiding Semnastek*, 2017.
- [5] G. W. Erwinda, S. A. Wibowo, and D. Rudhistiar, "IMPLEMENTASI FACE RECOGNITION DAN RFID SEBAGAI FITUR SECURITY PADA SMART HOME," *JATI (Jurnal Mahasiswa Teknik Informatika)*, vol. 6, no. 2, pp. 1123–1130, 2022.
- [6] S. H. Pratama, "RFID Sebagai Pengaman Pintu Laboratorium Jurusan Teknik Elektro Fakultas

Teknik Universitas Negeri Semarang," *Tugas Akhir Universitas Negeri Semarang, Semarang*, 2015.

- [7] W. P. Wicaksana and W. E. R. Sulistiyo, "Simulasi Overheating Warning Alarm System Untuk Internal Combustion Engine," *SEMNASTEKNOMEDIA ONLINE*, vol. 4, no. 1, pp. 2–9, 2016.